ABSTRACT

Image compression has become an important process in today's world of information exchange. It helps in effective utilization of high speed network resources. Medical image compression has an important role in medical field because they are used for future reference of patients. Medical data is compressed in such a way so that the diagnostics capabilities are not compromised or no medical information is lost. Medical imaging poses the great challenge of having compression algorithms that reduce the loss of fidelity as much as possible so as not to contribute to diagnostic errors and yet have high compression rates for reduced storage and transmission time. The medical image needs to undergo the process of compression before storing and transmitting it. Firstly, predictive encoding of the pixel values is done then it is transformed using wavelet transform then obtained variables are encoded by an entropy encoder.

KEYWORDS: Image Compression, Predictive Encoder, Integer Wavelet Transform, Lifting Wavelet Transform, Compression Efficiency, Entropy Encoder.

INTRODUCTION

Compression offers a means to reduce the cost of storage and increase the speed of transmission, thus medical images have attained a lot of attention towards compression. These images are very large in size and require lot of storage space. Therefore Image compression is required to minimize the storage space and reduction of transmission cost as well. It can be lossless and lossy, depending on whether all the information is retained or some of it is discarded during the compression process. In lossless compression, the recovered data is identical to the original the mapping of input data into bit sequences is done in such a way that the frequently encountered data will produce shorter output than less frequent data, whereas in the case of lossy compression the recovered data is a close replica of the original with minimal loss of data. Medical images are a special category of images in their characteristics and purposes. They are generally acquired from special equipment, such as computed tomography (CT), magnetic resonance (MRI), ultrasound (US), X-ray diffraction, electrocardiogram (ECG), and positron emission tomography (PET). Medical images like MRI and CT are special images requiring lossless compression because a minor loss of information can cause adverse effects on the medical report of the patient. Prediction is one of the techniques to achieve high compression. It means to estimate current data from already known data.

MEDICAL IMAGE COMPRESSION

The compression of medical images has a great demand. The image for compression can be a single image or sequence of images. Medical images are widely used for surgical plan and diagnosis purposes. They include human body pictures and are being present in digital form. Imaging devices improve every day and generate more data per patient. In the field of profiling patient's data, medical images need long-term storage. Therefore, images need compression. Tele-medicine application involves the image transmission within and among the health care organizations using public networks. Some typical requirements for compression of the medical data include high compression ratio and the ability to decode the compressed data at various resolutions. In addition to the compressing data, this requires the

handling of security issues when dealing with the sensitive medical information systems for storage, retrieval and distribution of the medical data

LOSSLESS COMPRESSION

A Lossless compression plays an important role in image compression in fields such as medical imaging, where due to information sensitivity and legal requirements no information can be removed from the image once it has been initially digitized. Compression of images normally consists of three steps: transformation, quantization, and codeword assignment. However, with lossless compression, and since quantization introduces quantization errors that prevent perfect reconstruction, lossless compression does not have a quantization step. The quantization step is normally used to turn the transformation coefficients from their float format to an integer format. With lossless compression, and to afford removing quantization, the algorithm must make use of a transform that yields only integer coefficients and allows for perfect reconstruction. Lossless compression algorithms make use of prediction based algorithms that only result in integer values. The prediction algorithm used is known and used by both the encoder and decoder of the image which allows it to be a perfect reconstruction transform. Regardless of the prediction algorithm used, the coefficients used for codeword assignment represent the difference between the predicted pixel value and the actual pixel value of the image. By making good predictions, the error is made small which in turn yields for shorter codeword assignments. Lossless compression consists of two major parts: transformation and coding. Input image goes through transformation and encoding steps and form in a shorter manner as a compressed bit stream. Many image compression algorithms use some form of transform coding.

The first step is to reduce the redundant bits for which predictive encoding is done. It is based on eliminating the redundancies of closely spaced pixels by extracting and coding only the new information in each pixel. The new information is defined as the difference between the actual and predicted value of the pixel. The second step is to obtain a mathematical transformation to the image pixels, in order to reduce the correlation between the pixels, integer wavelet transform is used. The result of the transform is known as the transform coefficients. The third step is entropy coding, which measures the amount of information present in the data or the degree of randomness of the data. The entropy coder encodes the given set of symbols with the minimum number of bits required to represent them. Hence we obtain a bit stream of compressed image. The reverse process occurs at the time of reconstruction. [Fig 1].

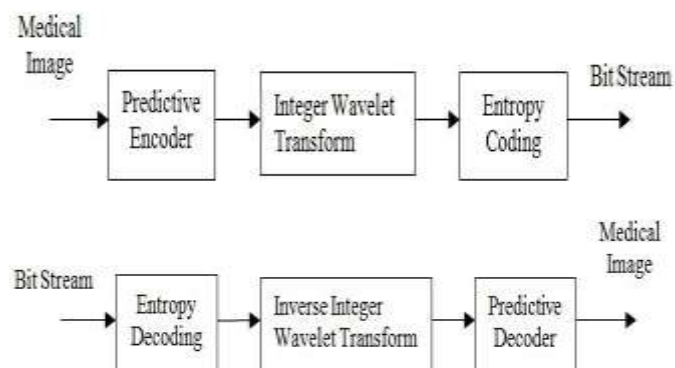

Fig. 1. Block diagram of Encoder and Decoder

PREDICTIVE ENCODER

Predictive encoding is a major class of encoding schemes that is utilized in lossless compression. Compression is accomplished by making use of the previously encoded pixels that are available to both the encoder and the decoder in order to predict the value for the next pixel to be encoded. Instead of the actual pixel value, the prediction error is then encoded Context-based predictions is a kind of adaptive predictive encoding in which pixels are classified into different classes based on pixel neighbourhood characteristics. The prediction technique computes the weighted differences between neighbouring pixel values to estimate the predicted pixel value. The prediction error is decomposed by a one-level integer wavelet transform to improve the prediction. The differences are taken between

the original sample and the sample(s) before the original sample. In Fig 2, Let $x[n]$ be the original sample and $\mu_p[n]$ be the predictor output then the difference $e[n]$ will be given by:

$$e[n] = x[n] - \mu_p[n]$$

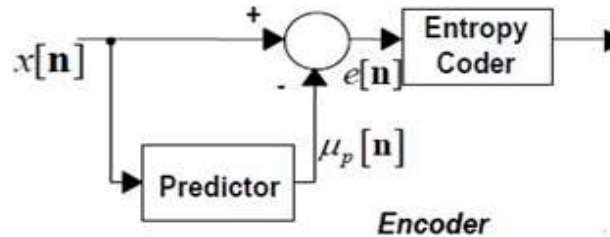

Fig 2. Lossless Predictive Encoder and Decoder

INTEGER WAVELET TRANSFORM

The wavelet transform is a very useful technique for image analysis, and Lifting Wavelet Transform is an advance form of wavelet transform which allows easy computation, better reconstruction of original image and close approximation of some data sets. The inter scale and intra scale dependencies of wavelet coefficients are exploited to find the predictor variable. The wavelet transform generally produces floating-point coefficients. Although the original pixels can be reconstructed by perfect reconstruction filters without any loss in principle, the use of finite-precision arithmetic and quantization prevents perfect reconstruction. The integer wavelet transform is based on the lifting scheme.

Lifting Scheme

The lifting scheme operates in three steps: split, prediction, and update. In this lifting scheme the Haar filter of the order one and one level decomposition is used. Filter coefficients of the Haar filter is given as ,

$$\begin{aligned} \text{Type I} \quad h_1 &= [-1 \ 9 \ 9 \ 1] / (16) \\ h_2 &= [0 \ 0 \ 1 \ 1] / (-4) \end{aligned}$$

where, h_1 is the prediction filter coefficient, and h_2 is update filter coefficient in the lifting scheme.

The filter coefficients of reduction are given by,

$$\begin{aligned} \text{Type II} \quad h_1 &= [-1 \ 9 \ 9 \ 1] / (16 * 1.5) \\ h_2 &= [0 \ 0 \ 1 \ 1] / (-4 * 1.5) \end{aligned}$$

A. Forward Lifting Scheme [Fig. 3]

a). Split Step

The split operation simply splits the signal s_i into even s_{i-1} and odd d_{i-1} subsets, as

$$\text{Split}(s_i) = (\text{even}_{i-1}; \text{odd}_{i-1}) = (s_{i-1}; d_{i-1})$$

The operation of obtaining the differences from the prediction is called the lifting step.

b). Prediction Step

Due to the high correlation between the odd and even coefficients in an image, the subset d_{i-1} can be predicted efficiently from subset s_{i-1} . Once the prediction is made, the signal s_i can be replaced by subset s_{i-1} and prediction error between the predicted d_{i-1} and the real values of d_{i-1} obtained from the split.

$$d_{j-1} = \text{Odd } j-1 - P(\text{Even } j-1)$$

c). Update Step

The update step is performed in order to enhance the subset s_{i-1} after the prediction step. The update step is needed because some of the properties in data set s_{i-1} don't match with these of the original data set. After the three steps are performed on the signal, the result will be low pass coefficients s_{i-1} and high pass coefficients d_{i-1} .

$$s_{j-1} = \text{Even } j-1 + U(d_{j-1})$$

The difference between the actual odd samples and the prediction becomes the wavelet coefficients. They become the scaling coefficients which will be passed on to the next stage of transform. This is the second lifting step.

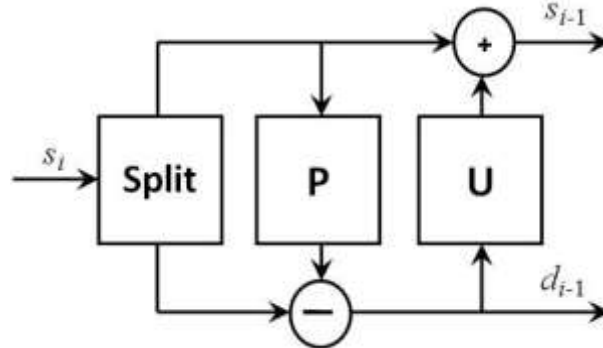

Fig.3. Forward Lifting Scheme

B. Reverse Lifting Scheme [Fig. 4]

Inverse transform gets back to original signal by exactly reversing operation with a merger operation to split. Even sample can be recovered by subtracting update information.

$$\text{Even}_{j-1} = S_{j-1} - U(d_{j-1})$$

Odd sample can be recovered by adding prediction.

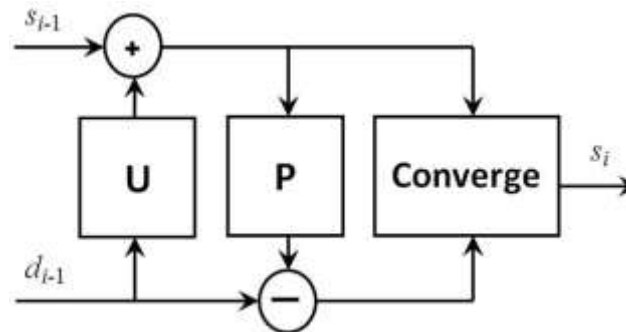

Fig.4. Reverse Lifting Scheme

ENTROPY ENCODER

Entropy measures the amount of information present in the data or the degree of randomness of the data. After the data has been quantized into a finite set of values it can be encoded using an entropy coder to achieve additional compression using probabilities of occurrence of data. The entropy coder encodes the given set of symbols with the minimum number of bits required to represent them. This technique reduces the statistical redundancy. It is a variable length coding which means that it assigns different number of bits to different gray levels

COMPRESSION EFFICIENCY

Compression efficiency is measured for lossless and lossy compression. For lossless coding it is simply measured by the achieved compression ratio for each one of the test images.

The most obvious measure of the compression efficiency is the bit rate, which gives the average number of bits per stored pixel of the image:









$$\text{Compression Ratio}(CR) = \frac{\text{size of uncompressed file}}{\text{size of compressed file}}$$

Lossless image compression must preserve every pixel intensity value regardless whether it is a noise or not. Efficiency of compression codec is usually described by compression ratio. Compression ratio is ratio between memory spaces needed to store raw image and memory space needed to store compressed data, i.e. code stream. Equivalent measure is bit rate, which shows how many bits per pixel are required for an image in average.

EXPERIMENT, RESULT AND DISCUSSION

Six medical images of different body parts having 256*256 pixels dimensions have been taken for experiment. In the result the calculation of entropy, peak signal to noise ratio (PSNR), compression ratio and mean square error (MSE) has been calculated.

Table 1. Original and Reconstructed images of different body parts

Body part	Original image	Reconstructed image
Brain		
Abdomen		
Knee		
Elbow		

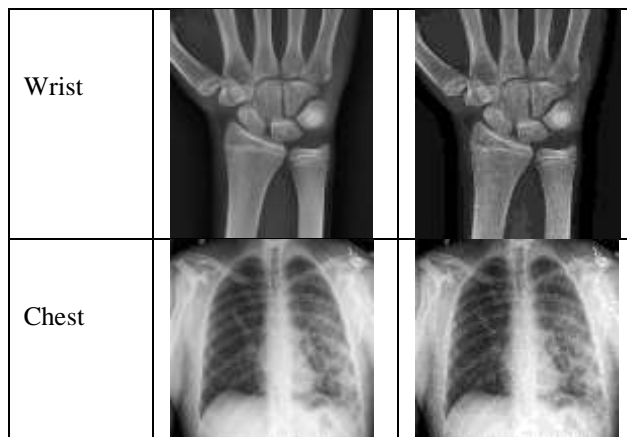

Table 2. Performance Chart

Image	Entropy	PSNR	Compression Ratio	MSE
Brain	0.975618	23.412559	2.202797	6255.84
Abdomen	0.945931	19.147173	2.110091	9583.61
Knee	0.983282	31.900580	6.744704	2677.04
Elbow	0.929178	21.769040	2.839285	7373.31
Wrist	0.921593	25.165961	2.630872	5249.72
Chest	0.997389	11.375753	2.815126	20846.7

CONCLUSION

In this paper I have studied about one of the various methods of lossless medical image compression. Integer wavelet transform is one of the method to obtain the lossless image and predictive encoder is necessary to compress the medical image size, so that we can obtain a good quality medical image without paying the cost of increased size and bandwidth.

ACKNOWLEDGMENT

I want to thanks my guide Mr. Narendra Kumar Chaurasia sir (Asstt. Prof.) of Buddha Institute of Technologyv and Mr. Arun Kumar Mishra sir (Dean) of Buddha Institute of Technology for their support that has made this work possible.

REFERENCES

- [1] Mohamed M. Fouad. "A Lossless Image Compression Using Integer Wavelet Transform with a Simplified Median-edge Detector Algorithm". International Journal of Engineering & Technology IJET-IJENS Vol: 15 No: 04, ISSN 155604-7373.
- [2] Komal Gupta, Ram Lautan Verma, Md. Sanawer Alam. "Lossless Medical Image Compression using Predictive Coding and Integer Wavelet Transform based on Minimum Entropy Criteria". International Journal of Application or Innovation in Engineering & Management (IJAIEEM). Volume 2, Issue 8, August 2013, ISSN 2319 – 4847.
- [3] Rohini N. Shrikhande, Dr. V. K. Bairagi. "Comparison of different methods for lossless medical image Compression". Global Journal of Engineering, Design & Technology (GJEDT). Vol. 2(3) 2013:36-40, ISSN: 2319 – 7293.
- [4] LakshmiPriya. S, Maya John." Medical image compression using anamorphic stretch transform". International journal of engineering sciences & research Technology (IJESRT). October, 2015, ISSN: 2277-9655.

- [5] S.M.Ramesh, Dr.A.Shanmugam. "Medical Image Compression using Wavelet Decomposition for Prediction Method". International Journal of Computer Science and Information Security (IJCSIS). Vol. 7, No. 1, 2010.
- [6] Shalini Prasad, Prashant Ankur Jain and Satendra Singh. "Lossless medical image compression by IWT". Pelagia Research Library Advances in Applied Science Research, 2015, 6(12): 32-36. ISSN: 0976-8610.
- [7] Nagashree G, Gadre Vaishali, and Mrs Vijaya S M. "Lossless Medical Image Compression. International". Journal of Engineering Research and Applications ISSN: 2248-9622, Vol. 4, Issue 6(Version 5), June 2014, pp.07-11.
- [8] Vipul Sharan, Naveen Keshari, Tanay Mondal. "Biomedical Image Denoising and Compression in Wavelet using MATLAB". International Journal of Innovative Science and Modern Engineering (IJISME) ISSN: 2319-6386, Volume-2, Issue-6, May 2014.